

**Grinding Unit
RT02**

Grinding cutter, LOW-NOISE, 45° tips inclination

Characteristics:

Finishing cutters for single shoulder edge banding machine

Design:

LOW-NOISE with significative noise reduction during the working process
45° brazed-welded pushing tips with axial inclination for a high-quality finishing cut

RPM: 9.000/12.000

Materials: chipboard, melamine, honeycomb wood, veneered panels, MDF

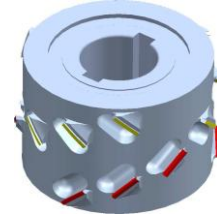
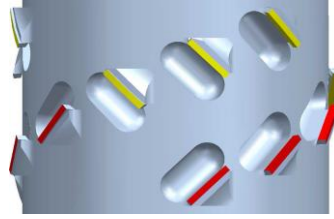

Wirutex Code	Biesse Code	Description
S13165	CSEN350085	PCD CUTTER D.80X49X30+2KW Z=3+3 SYMM. 45° LOW-NOISE
S13164	CSEN350086	PCD CUTTER D.80X65X30+2KW Z=3+3 SYMM. 45° LOW-NOISE
S13076		PCD CUTTER D.80X49X30+2KW Z=2+2 SYMM. 45° LOW-NOISE
S12805		PCD CUTTER D. 80X65X30+2KW Z=2+2 SYMM. 45° LOW-NOISE

**End Cutting Unit
IN - 801**

End cutting unit with alternate tooth for Akron 1400

Characteristics:
End cutting of glued edges

Design:
Alternate tooth + smoothings

RPM:
12.000

Materials:
Solid wood edges, supported edges, plastic edges

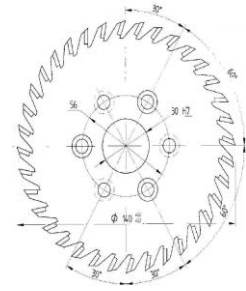
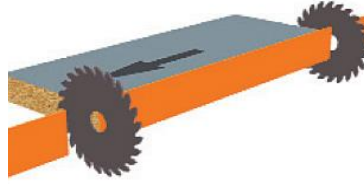

Wirutex Code	Biesse Code	Description
D02543	N3401N0503	HM SAW BLADE D.140X3,6X30+3+3 Z=36 ALTERNATE TOOTH

**Overlapped Trimmer Unit
RS - 502**

Overlapped trimmers with HM interchangeable knives

Characteristics:
For edge trimming

Design:
With interchangeable HM knives

RPM:
18.000

Materials:
Solid wood edges, supported edges, plastic edges

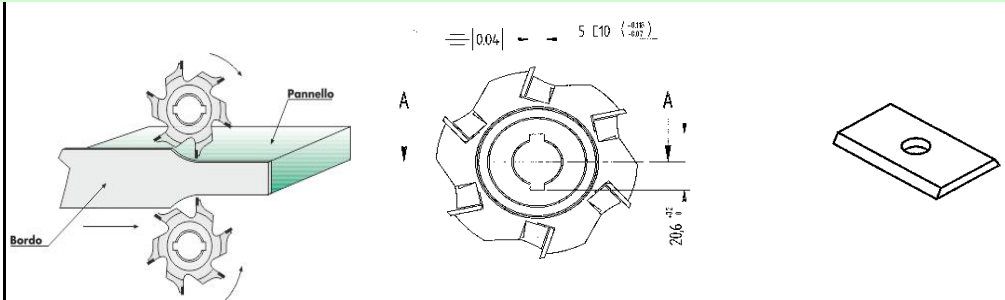

Wirutex Code	Biesse Code	Description
D02126	N3401N0430	HM CUTTER WITH KNIVES D.70X20X16+2KW Z=6
C00403	N3402N0040	HM KNIFE 20X12X1,5

**Tilted Trimmer
RI - 501**

Trimmer for tilted engines with HM interchangeable knives

Characteristics:
For edge trimming on tilted engines

Design:
With HM exchangeable knives for chamfers and radiuses R1 - R1,5 - R2 - R3
1 radius each cutter

RPM:
18.000

Materials:
Solid wood edges, supported edges, plastic edges

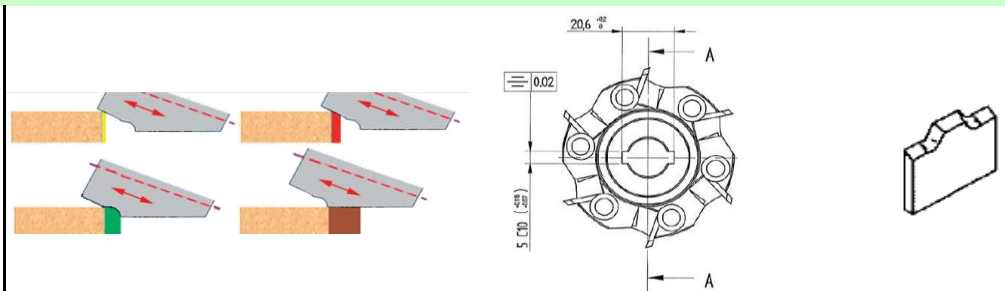

Wirutex Code	Biesse Code	Description
D02126	N3401N0430	HM CUTTER WITH KNIVES D.70X20X16+2KW Z=6
C00403	N3402N0040	HM KNIFE 20X12X1,5
D02368	N3401N0431	HM CUTTER WITH KNIVES D.70X20X16+2KW R=1 Z=6
D02372	N3402N0123	HM KNIFE R=1
D02369	N3401N0432	HM CUTTER WITH KNIVES D.70X20X16+2KW R=1.5 Z=6
D02373	N3402N0124	HM KNIFE R=1.5
D02370	N3401N0433	HM CUTTER WITH KNIVES D.70X20X16+2KW R=2 Z=6
D02374	N3402N0125	HM KNIFE R=2
D02127	N3401N0434	HM CUTTER WITH KNIVES D.70X20X16+2KW R=3 Z=6
D02134	N3402N0126	HM KNIFE R=3

**Tilted Trimmer
RF-02 / RF-501**

Trimmer for tilted engines with HM interchangeable knives

Characteristics:

For edge trimming on tilted engines.
Fixed motor tilted at 25°.

Design:

With HM interchangeable knives for chamfers and radiuses R1 - R1,5 - R2 - R3
1 radius each cutter

RPM:

18.000

Materials:

Solid wood edges, supported edges, plastic edges

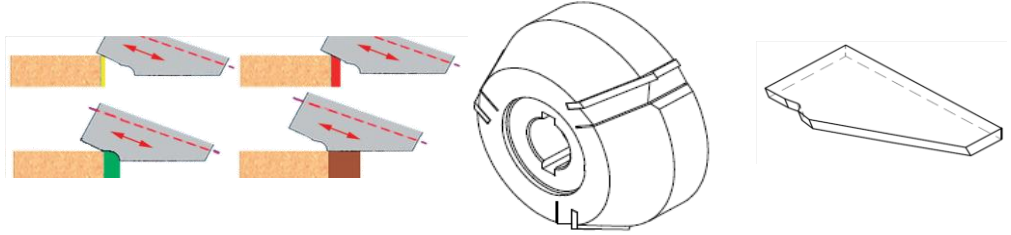

Wirutex Code	Biesse Code	Description
D03647	CSEN350013	HM CUTTER WITH KNIVES D.72X30X16+2KW 25° Z=3 CW.
D03648	CSEN700013	HM KNIFE 25°
D03649	CSEN350014	HM CUTTER WITH KNIVES D.72X30X16+2KW 25° Z=3 CCW.
D03650	CSEN700014	HM KNIFE 25°
D03651	CSEN350015	HM CUTTER WITH KNIVES D.72X30X16+2KW R=1 Z=3 CW.
D03652	CSEN700015	HM KNIFE R=1
D03653	CSEN350016	HM CUTTER WITH KNIVES D.72X30X16+2KW R=1 Z=3 CCW.
D03655	CSEN350017	HM CUTTER WITH KNIVES D.72X30X16+2KW R=1.5 Z=3 CW.
D03656	CSEN700017	HM KNIFE R=1.5
D03657	CSEN350018	HM CUTTER WITH KNIVES D.72X30X16+2KW R=1.5 Z=3 CCW.
D03658	CSEN700018	HM KNIFE R=1.5
D03659	CSEN350019	HM CUTTER WITH KNIVES D.72X30X16+2KW R=2 Z=3 CW.
D03660	CSEN700019	HM KNIFE R=2
D03661	CSEN350020	HM CUTTER WITH KNIVES D.72X30X16+2KW R=2 Z=3 CCW.
D03662	CSEN700020	HM KNIFE R=2
D03663	CSEN350021	HM CUTTER WITH KNIVES D.72X30X16+2KW R=3 Z=3 CW.
D03664	CSEN700021	HM KNIFE R=3
D03665	CSEN350022	HM CUTTER WITH KNIVES D.72X30X16+2KW R=3 Z=3 CCW.
D03666	CSEN700022	HM KNIFE R=3

Multiprofile Tilted Trimmer RF-02/ RI-501

Trimmer for tilted engines with **HM multiprofile interchangeable knives**

Characteristics:

For edge trimming on tilted engines

Design:

With HM exchangeable knives for chamfers and radiuses R1 - R1,5 - R2 - R3
2 radiuses each cutter

RPM:

18.000

Materials:

Solid wood edges, supported edges, plastic edges

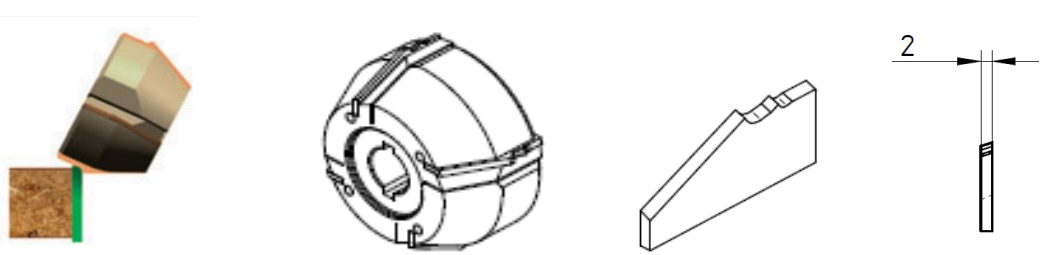

Wirutex Code	Biesse Code	Description
D03667	CSEN350023	HM CUTTER WITH KNIVES D.72.19X35X16+2KW R=1/1.5 Z=4 CW.
D03668	CSEN700023	HM KNIFE R=1/1.5
D03669	CSEN350024	HM CUTTER WITH KNIVES D.72.19X35X16+2KW R=1/1.5 Z=4 CCW.
D03670	CSEN700024	HM KNIFE R=1/1.5
D03671	CSEN350025	HM CUTTER WITH KNIVES D.72.19X35X16+2KW R=1/2 Z=4 CW.
D03672	CSEN700025	HM KNIFE R=1/2
D03673	CSEN350026	HM CUTTER WITH KNIVES D.72.19X35X16+2KW R=1/2 Z=4 CCW.
D03674	CSEN700026	HM KNIFE R=1/2
D03675	CSEN350027	HM CUTTER WITH KNIVES D.72.19X35X16+2KW R=1.5/2 Z=4 CW.
D03676	CSEN700027	HM KNIFE R=1.5/2
D03677	CSEN350028	HM CUTTER WITH KNIVES D.72.19X35X16+2KW R=1.5/2 Z=4 CCW.
D03678	CSEN700028	HM KNIFE R=1.5/2
D03679	CSEN350029	HM CUTTER WITH KNIVES D.72.19X35X16+2KW R=1.5/3 Z=4 CW.
D03680	CSEN700029	HM KNIFE R=1.5/3
D03681	CSEN350030	HM CUTTER WITH KNIVES D.72.19X35X16+2KW R=1.5/3 Z=4 CCW.
D03682	CSEN700030	HM KNIFE R=1.5/3
D03683	CSEN350031	HM CUTTER WITH KNIVES D.72.19X35X16+2KW R=2/3 Z=4 CW.
D03684	CSEN700031	HM KNIFE R=2/3
D03685	CSEN350032	HM CUTTER WITH KNIVES D.72.19X35X16+2KW R=2/3 Z=4 CCW.
D03686	CSEN700032	HM KNIFE R=2/3

Rounding Unit AR02-E

Rounding cutter with **HM interchangeable knives**

Characteristics:

For edge spoking

Design:

With HM exchangeable knives for chamfers and radiuses R1 - R1,5 - R2 - R3
1 radius each cutter

RPM:

18.000

Materials:

Solid wood edges, supported edges, plastic edges

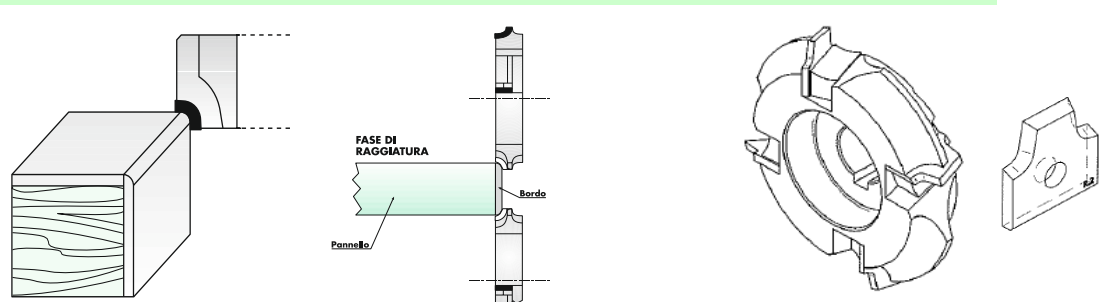

Wirutex Code	Biesse Code	Description
D03252	3401A0353	HM CUTTER WITH KNIVES D.70X20X16+2KW R=1.5 Z=4 20° CW.
D03253	3401A0354	HM CUTTER WITH KNIVES D.70X20X16+2KW R=1.5 Z=4 20° CCW.
D03254	3402A0086	HM KNIFE 16X16.5X2 R=1.5
D03255	3401A0355	HM CUTTER WITH KNIVES D.70X20X16+2KW R=1 Z=4 20° CW.
D03256	3401A0356	HM CUTTER WITH KNIVES D.70X20X16+2KW R=1 Z=4 20° CCW.
D03257	3402A0087	HM KNIFE 16X16.5X2 R=1
D03246	3401A0349	HM CUTTER WITH KNIVES D.70X20X16+2KW R=2 Z=4 20° CW.
D03247	3401A0350	HM CUTTER WITH KNIVES D.70X20X16+2KW R=2 Z=4 20° CCW.
D03248	3402A0084	HM KNIFE 16X16.5X2 R=2
D03249	3401A0351	HM CUTTER WITH KNIVES D.70X20X16+2KW R=3 Z=4 20° CW.
D03250	3401A0352	HM CUTTER WITH KNIVES D.70X20X16+2KW R=3 Z=4 20° CCW.
D03251	3402A0085	HM KNIFE 16X16.5X2 R=3

Rounding Unit AR02-E

Rounding cutter with **HM brazed-welded tips**

Characteristics:
For edge spoking

Design:
With HM brazed-welded tips for chamfers and radiuses R1 - R1,5 - R2 - R3
1 radius each cutter

RPM:
18.000

Materials:
Solid wood edges, supported edges, plastic edges



Wirutex Code	Biesse Code	Description
D01578	N3401N0112	HM BRAZED-WELDED CUTTER D.60/68 B=16+2KW R=1 Z=6 CW.
D01579	N3401N0113	HM BRAZED-WELDED CUTTER D.60/68 B=16+2KW R=1 Z=6 CCW.
D01529	N3401N0107	HM BRAZED-WELDED CUTTER D.60/68 B=16+2KW R=1 .5 Z=6 CW.
D01580	N3401N0108	HM BRAZED-WELDED CUTTER D.60/68 B=16+2KW R=1 .5 Z=6 CCW.
D01482	N3401N0105	HM BRAZED-WELDED CUTTER D.60X9X16+2KW 25° Z=6 CW.
D01483	N3401N0106	HM BRAZED-WELDED CUTTER D.60X9X16+2KW 25° Z=6 CCW.
D01527	N3401N0103	HM BRAZED-WELDED CUTTER D.60/68 B=16+2KW R=3 Z=6 CW.
D01528	N3401N0104	HM BRAZED-WELDED CUTTER D.60/68 B=16+2KW R=3 Z=6 CCW.
D01522	N3401N0101	HM BRAZED-WELDED CUTTER D.60X9X16+2KW 25° Z=6 CW.
D01523	N3401N0102	HM BRAZED-WELDED CUTTER D.60X9X16+2KW 25° Z=6 CCW.

Rounding Unit AR02-E

Fine trimming cutter with **PCD brazed-welded tips**

Characteristics:
For edge fine trimming

Design:
Cutters with straight PCD tips, brazed-welded by induction machine with optical/electronic control

RPM: 12.000/15.000

Materials:
Solid wood edges, supported edges, plastic edges



Wirutex Code	Biesse Code	Description
S06800	N3401N0089	PCD CUTTER D.58,8X11X16+2CH 25° Z=6 CW.
S06801	N3401N0090	PCD CUTTER D.58,8X11X16+2CH 25° Z=6 CCW.
S14451	N3401N0110	PCD CUTTER D.60X11X16+2CH R=1 Z=6 CW.
S14450	N3401N0111	PCD CUTTER D.60X11X16+2CH R=1 Z=6 CCW.
S13811	N3401N0095	PCD CUTTER D.60X11X16+2CH R=1.5 Z=6 CW.
S13810	N3401N0096	PCD CUTTER D.60X11X16+2CH R=1.5 Z=6 CCW.
S14234	N3401N0093	PCD CUTTER D.60X11X16+2CH R=2 Z=6 CW.
S14233	N3401N0094	PCD CUTTER D.60X11X16+2CH R=2 Z=6 CCW.
S14453	N3401N0091	PCD CUTTER D.60X11X16+2CH R=3 Z=6 CW.
S14452	N3401N0092	PCD CUTTER D.60X11X16+2CH R=3 Z=6 CCW.

**Edge Scraper
RB02**

HM ANTI-BLEACHING edge scraper insert

Characteristics:
For edge finishing

Design:
HM solid rounding insert, with ANTI-BLEACHING profile

Materials:
Solid wood edges, supported edges, plastic edges

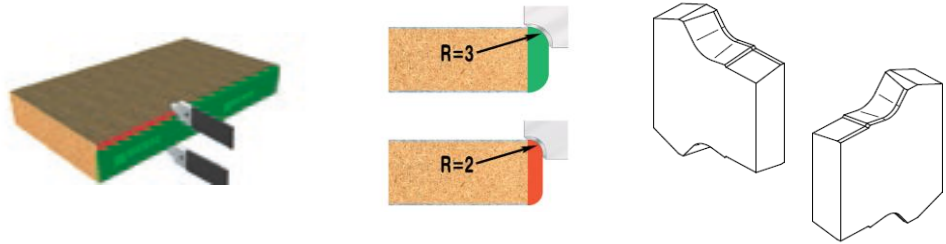

Wirutex Code	Biesse Code	Description
D03413	3402A0083	RB INSERT 13.5X11X3 25° ANTI-BLEACHING
D03607	3402A0124	RB INSERT R=1.0 ANTI-BLEACHING
D03608	3402A0125	RB INSERT R=1.5 ANTI-BLEACHING
D03609	3402A0126	RB INSERT R=2.0 ANTI-BLEACHING
D03222	3402A0082	RB INSERT 13.5X11X3 R=3.0 ANTI-BLEACHING

**Glue Scraper
RC02**

HM Glue scraper insert

Caratteristiche:
To remove residual glue after edge bonding process

Design:
Triangular insert with 3 cutting edges

Materials:
Solid wood edges, supported edges, plastic edges

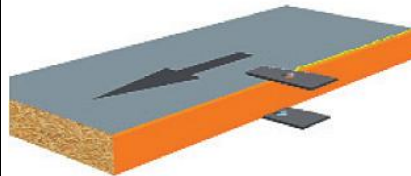

Wirutex Code	Biesse Code	Description
C00626	E3401E0117	TRIANGULAR INSERT 22,86X2,5 Z=3